



User Guide

SM-Encoder Plus SM-Encoder Output Plus

Solutions Module for:

Unidrive SP
Digitax ST

Part Number: 0471-0026-04
Issue: 4

General Information

The manufacturer accepts no liability for any consequences resulting from inappropriate, negligent or incorrect installation or adjustment of the optional operating parameters of the equipment or from mismatching the variable speed drive with the motor.

The contents of this guide are believed to be correct at the time of printing. In the interests of a commitment to a policy of continuous development and improvement, the manufacturer reserves the right to change the specification of the product or its performance, or the contents of this guide, without notice.

All rights reserved. No parts of this guide may be reproduced or transmitted in any form or by any means, electrical or mechanical including photocopying, recording or by an information storage or retrieval system, without permission in writing from the publisher.

Drive software version

The SM-Encoder Plus and SM-Encoder Output Plus can only be used with the following drive software versions:

	SM-Encoder Plus	SM-Encoder Output Plus
Unidrive SP	≥V01.02.00	≥V01.13.00
Digitax ST	≥V01.00.00	≥V01.00.00

If a SM-Encoder Output Plus module is fitted to a Unidrive SP with software version earlier than V01.13.00, the module will operate as a SM-Encoder Plus module.

Contents

1	How to use this guide	4
1.1	Intended personnel	4
1.2	Information	4
2	Safety information	5
2.1	Warnings, Cautions and Notes	5
2.2	Electrical safety - general warning	5
2.3	System design and safety of personnel	5
2.4	Environmental limits	6
2.5	Compliance with regulations	6
2.6	Motor	6
2.7	Adjusting parameters	6
3	Introduction	7
3.1	Features	7
3.2	Solutions Module identification	7
3.3	Set-up parameters	8
3.4	Compatible encoder types	8
3.5	Simulated outputs (SM-Encoder Output Plus only)	9
4	Installing the Solutions Module	10
4.1	General Installation	10
4.2	Terminal descriptions	11
4.3	Wiring, Shield connections	12
5	Getting started	17
5.1	Installation	17
5.2	Incremental set-up	18
5.3	Simulated encoder output set-up	19
5.4	Freeze function	19
5.5	Termination resistors	19
6	Parameters	20
6.1	Introduction	20
6.2	Single line descriptions	22
6.3	Parameter descriptions	28
7	Diagnostics	35
7.1	Displaying the trip history	35
8	Terminal data	38
8.1	Encoder inputs (PL1)	38
8.2	Encoder Outputs (PL2)	39

1 How to use this guide

1.1 Intended personnel

This guide is intended for personnel who have the necessary training and experience in system design, installation, commissioning and maintenance.

1.2 Information

This guide contains information covering the identification of the Solutions Module, terminal layout for installation, fitting of the Solutions Module to the drive, parameter details and diagnosis information. Additional to the aforementioned are the specifications of the Solutions Module.

2 Safety information

2.1 Warnings, Cautions and Notes



A **Warning** contains information, which is essential for avoiding a safety hazard.



A **Caution** contains information, which is necessary for avoiding a risk of damage to the product or other equipment.

NOTE A **Note** contains information, which helps to ensure correct operation of the product.

2.2 Electrical safety - general warning

The voltages used in the drive can cause severe electrical shock and/or burns, and could be lethal. Extreme care is necessary at all times when working with or adjacent to the drive.

Specific warnings are given at the relevant places in this User Guide.

2.3 System design and safety of personnel

The drive is intended as a component for professional incorporation into complete equipment or a system. If installed incorrectly, the drive may present a safety hazard.

The drive uses high voltages and currents, carries a high level of stored electrical energy, and is used to control equipment which can cause injury.

Close attention is required to the electrical installation and the system design to avoid hazards, either in normal operation or in the event of equipment malfunction. System design, installation, commissioning / start up and maintenance must be carried out by personnel who have the necessary training and experience. They must read this safety information and this User Guide carefully.

The STOP and SECURE DISABLE / SAFE TORQUE OFF functions of the drive do not isolate dangerous voltages from the output of the drive or from any external option unit. The supply must be disconnected by an approved electrical isolation device before gaining access to the electrical connections.

With the sole exception of the SECURE DISABLE / SAFE TORQUE OFF function, none of the drive functions must be used to ensure safety of personnel, i.e. they must not be used for safety-related functions.

The SECURE DISABLE function and secure input on Unidrive SP and the SAFE TORQUE OFF function of the Digitax ST meet the requirements of EN954-1 category 3 for the prevention of unexpected starting of the drive. They may be used in a safety-related application. **The system designer is responsible for ensuring that the complete system is safe and designed correctly according to the relevant safety standards.**

Careful consideration must be given to the functions of the drive which might result in a hazard, either through their intended behaviour or through incorrect operation due to a fault. In any application where a malfunction of the drive or its control system could lead to or allow damage, loss or injury, a risk analysis must be carried out, and where

necessary, further measures taken to reduce the risk - for example, an over-speed protection device in case of failure of the speed control, or a fail-safe mechanical brake in case of loss of motor braking.

2.4 Environmental limits

Instructions in the appropriate drive manual regarding transport, storage, installation and use of the drive must be complied with, including the specified environmental limits. Drives must not be subjected to excessive physical force.

2.5 Compliance with regulations

The installer is responsible for complying with all relevant regulations, such as national wiring regulations, accident prevention regulations and electromagnetic compatibility (EMC) regulations. Particular attention must be given to the cross-sectional areas of conductors, the selection of fuses or other protection, and protective earth (ground) connections.

The appropriate drive manual contains instruction for achieving compliance with specific EMC standards.

Within the European Union, all machinery in which this product is used must comply with the following directives:

98/37/EC: Safety of machinery.

89/336/EEC: Electromagnetic Compatibility.

2.6 Motor

Ensure the motor is installed in accordance with the manufacturer's recommendations. Ensure the motor shaft is not exposed.

Standard squirrel cage induction motors are designed for single speed operation. If it is intended to use the capability of the drive to run a motor at speeds above its designed maximum, it is strongly recommended that the manufacturer is consulted first.

Low speeds may cause the motor to overheat because the cooling fan becomes less effective. The motor should be fitted with a protection thermistor. If necessary, an electric forced vent fan should be used.

The values of the motor parameters set in the drive affect the protection of the motor. The default values in the drive should not be relied upon.

It is essential that the correct value is entered in parameter **0.46** motor rated current. This affects the thermal protection of the motor.

2.7 Adjusting parameters

Some parameters have a profound effect on the operation of the drive. They must not be altered without careful consideration of the impact on the controlled system.

Measures must be taken to prevent unwanted changes due to error or tampering.

3 Introduction

3.1 Features

The SM-Encoder Plus and SM-Encoder Output Plus Solutions Modules provide an interface for an additional encoder to be connected to the drive, to be used as position and speed feedback for the drive. Typical uses for these Solutions Modules would be to input a speed/position reference from a line speed encoder, or to digitally lock the drive to a master reference using the position controller in drive menu 13.

The SM-Encoder Output Plus has all the features of the SM-Encoder Plus module but also provides an encoder power supply output and simulated encoder outputs.

NOTE The SM-Encoder Plus does not have any simulated encoder outputs or an encoder power supply output available.

3.2 Solutions Module identification

Figure 3-1 SM-Encoder Plus and SM-Encoder Output Plus

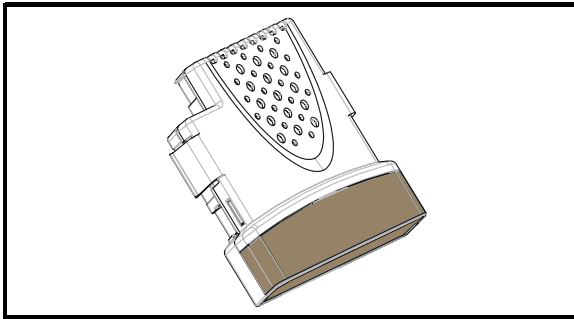

The SM-Encoder Plus and SM-Encoder Output Plus can be identified by:

1. The label located on the underside of the Solutions Module.
2. The colour coding across the front of the Solutions Module.
SM-Encoder Plus: Brown
SM-Encoder Output Plus: Dark Brown

Figure 3-2 SM-Encoder Plus and SM-Encoder Output Plus label

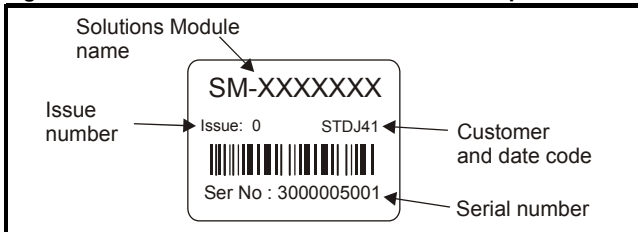

3.2.1 Date code format

The date code is split into two sections: a letter followed by a number.

The letter indicates the year, and the number indicates the week number (within the year) in which the Solutions Module was built.

The letters go in alphabetical order, starting with A in 1990 (B in 1991, C in 1992 etc.).

Example:

A date code of L35 would correspond to week 35 of year 2002.

3.3 Set-up parameters

All parameters associated to the SM-Encoder Plus or SM-Encoder Output Plus can be found in either menu 15, 16, or 17. Each of menus 15, 16, and 17 refer to one of the available slots into which the Solutions Module can be fitted. Slot 1 = Menu 15, Slot 2 = Menu 16, Slot 3 = Menu 17.

NOTE There are only two available slots for Unidrive SP size 0 and Digitax ST.

3.4 Compatible encoder types

The SM-Encoder Plus and SM-Encoder Output Plus are compatible with the following encoders types:

Incremental encoders Ab, Fd, and Fr

This type of encoder gives incremental position and can only be used for control in Closed Loop Vector and not Servo mode.

Type	Encoder	Description	Pr x.15
Incremental	Ab	Quadrature incremental encoder. With or without marker pulse.	0
	Fd	Incremental encoder with frequency and direction outputs. With or without marker pulse.	1
	Fr	Incremental encoder with forward and reverse outputs. With or without marker pulse.	2

Quadrature detection logic determines rotation from the phase relationship of the two channels.

These encoders are available with a marker pulse, which identifies each individual rotation of the disc, and is also used to reset the drive position parameter. The incremental encoder can be used when operating in Closed Loop Vector mode, with the optional marker pulse not being required for correct operation.

Limitations			
Type	Encoder	Max Input Frequency	Max no. of Lines (LPR)
Incremental	Ab	500kHz*	16,384
	Fd		
	Fr		

* Max input frequency = LPR x rpm / 60

NOTE The maximum speed in rpm which an encoder connected to the SM-Encoder Plus or SM-Encoder Output Plus can reach can be calculated from :

$$\text{Max rpm} = (60 \times \text{Max input frequency}) / \text{Encoder LPR}$$

e.g. For a 4096 line encoder the maximum rpm would be:

$$(60 \times 500 \times 10^3) / 4096 = 7324\text{rpm}$$

Figure 3-3 Encoder feedback signals

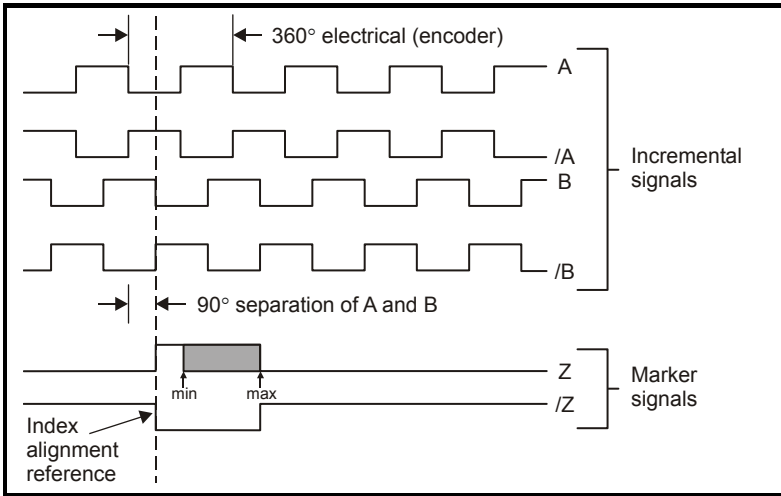

NOTE Only encoders with lines per revolution that are a power of 2 can be used with the SM-Encoder Plus and SM-Encoder Output Plus, e.g. 256, 512, 1024 etc. The marker pulse duration must be between 45° to 360° electrical (encoder).

3.5 Simulated outputs (SM-Encoder Output Plus only)

The SM-Encoder Output Plus can provide simulated encoder output signals. The source position is derived from either the encoder input on the module or from the drive encoder input. The source encoder can be any incremental type or any sincos type of encoder. If a sincos type is used as the source, the simulation output is derived from the zero crossings of the sine waves and does not include interpolated information.

Mode	x.28
Quadrature outputs	0
Frequency and direction outputs	1
Forward and reverse outputs	2
Quadrature outputs with marker lock	3
Frequency and direction outputs with marker lock	4 to 7

If a mode with marker lock is selected the incremental position is shifted when the first input marker occurs so that with quadrature mode the marker is aligned with A high and B high, and with frequency and direction mode the marker is aligned with F high.

The SM-Encoder Output Plus provides the ability to scale down the simulated encoder output signals.

4 Installing the Solutions Module



Before installing or removing a Solutions Module in any drive, ensure the AC supply has been disconnected for at least 10 minutes and refer to Chapter 2 *Safety information* on page 5. If using a DC bus supply ensure this is fully discharged before working on any drive or Solutions Module.

4.1 General Installation

The installation of a Solutions Module is illustrated in Figure 4-1.

Figure 4-1 Fitting a Solutions Module

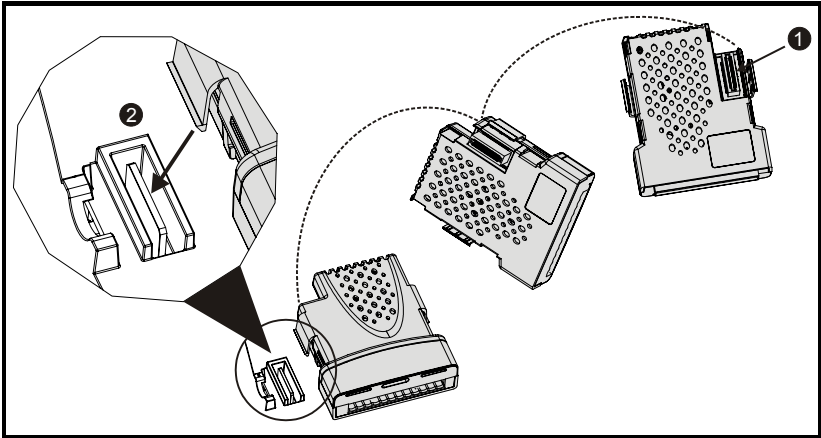

The Solutions Module connector is located on the underside of the module (1). Push this into the Solutions Module slot located on the drive until it clicks into place (2). Note that some drives require a protective tab to be removed from the Solutions Module slot. For further information, refer to the appropriate drive manual.

4.2 Terminal descriptions

4.2.1 SM-Encoder Plus

Figure 4-2 SM-Encoder Plus terminals

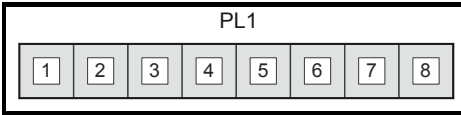

Table 4.1 SM-Encoder Plus terminal descriptions

Term	Encoder		
	Ab	Fd	Fr
1	A	F	F
2	A\	F\	F\
3	B	D	R
4	B\	D\	R\
5	Z		
6	Z\		
7	0V		
8	External power supply decoupling		

NOTE

Terminal 8 should be used to join the external encoder power supply to the encoder as shown in Figure 4-3. If the drive encoder supply is to be used for two encoders, the user must ensure the total load does not exceed 300mA for 5V and 8V encoders and 200mA for 15V encoders.

Figure 4-3 Encoder cable connections

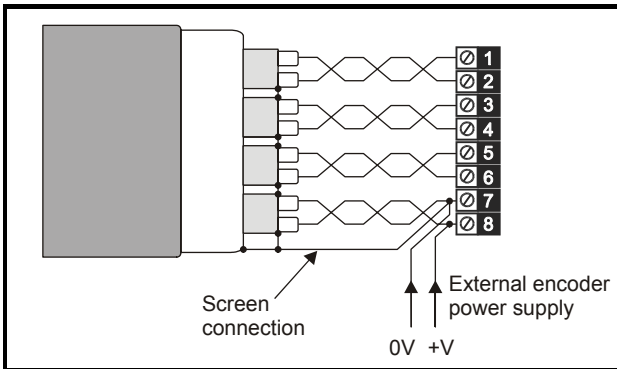

4.2.2 SM-Encoder Output Plus

Figure 4-4 SM-Encoder Output Plus terminals

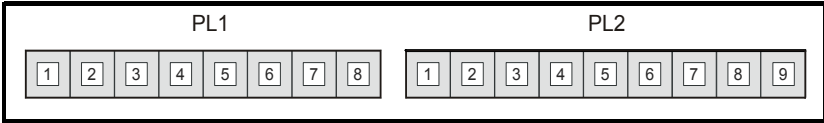

Table 4.2 SM-Encoder Output Plus PL1 terminal descriptions

Term	Encoder inputs		
	Ab	Fd	Fr
1	A	F	F
2	A\	F\	F\
3	B	D	R
4	B\	D\	R\
5	Z		
6	Z\		
7	0V		
8	+V		

Table 4.3 SM-Encoder Output Plus PL2 terminal descriptions

Term	Encoder outputs				
	Ab	Fd	Fr	Ab.L	Fd.L
1	0V				
2	0V				
3	A	F	F	A	F
4	A\	F\	F\	A\	F\
5	B	D	R	B	D
6	B\	D\	R\	B\	D\
7	0V				
8	Z				
9	Z\				

4.3 Wiring, Shield connections

Shielding considerations are important for PWM drive installations due to the high voltages and currents present in the output circuit with a very wide frequency spectrum, typically from 0 to 20 MHz. Encoder inputs are liable to be disturbed if careful attention is not given to managing the cable shields.

Encoder mounting methods

There are three methods for mounting an encoder onto a motor:

1. Galvanic isolation between encoder and motor
2. Galvanic isolation between encoder circuit and encoder body
3. No Isolation

4.3.1 Encoder with galvanic isolation from motor

When galvanically isolated the encoder device is mounted to the motor with isolation fitted between the motor housing / shaft and encoder as shown in Figure 4-5.

Figure 4-5 Galvanic Isolation from motor

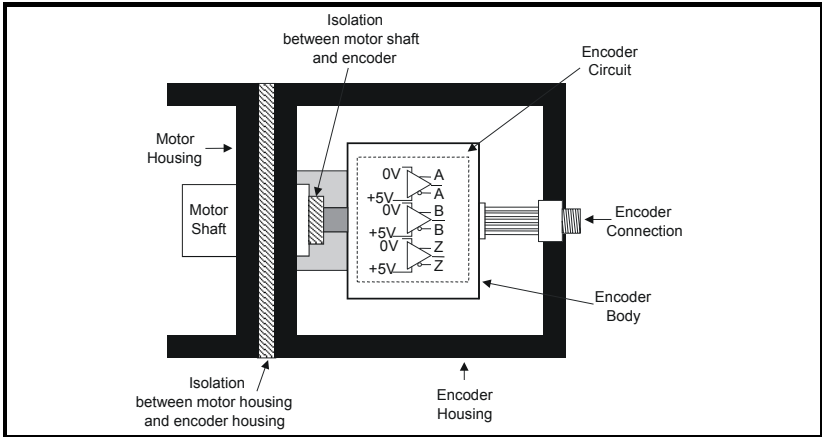

An example of this is the Unimotor where isolation from the motor is achieved by inserting a plastic mounting plate between the motor housing and encoder housing and a plastic insert fitted in the motor shaft for encoder mounting to the motor shaft. With this preferred method of mounting noise current is prevented from passing from the motor housing into the encoder housing, and hence into the encoder cable. The ground connection of the cable shield is optional, this may be required to comply with safety measures or to reduce radiated radio frequency emissions from either the drive or encoder.

4.3.2 Encoder circuit with galvanic isolation from encoder body

In this case the encoder device is mounted directly on the motor housing with contact being made between the motor housing/shaft and encoder. With this mounting method the encoder internal circuits are exposed to electrical noise from the motor housing through the stray capacitance, and they must be designed to withstand this situation. However this arrangement still prevents large noise currents from flowing from the motor body into the encoder cable. The ground connection of the cable shield is optional, this may be required to comply with safety measures or to reduce radiated radio frequency emissions from either the drive or encoder.

Figure 4-6 Encoder galvanically isolated from encoder body

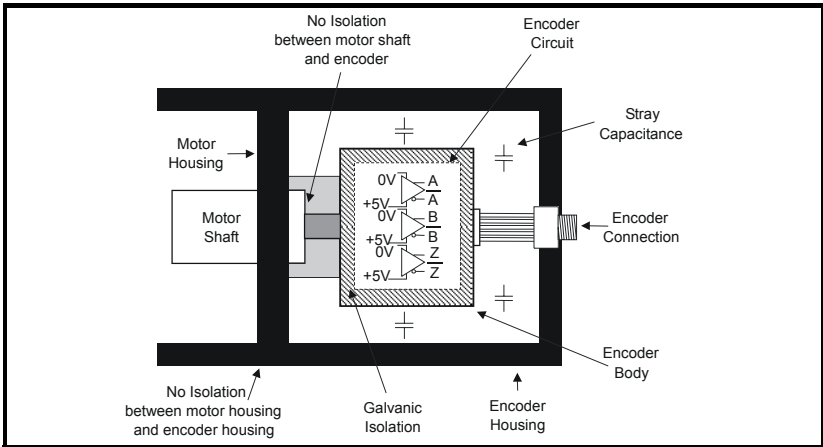

4.3.3 No isolation

As shown in Figure 4-7 the encoder 0V connection may be permanently connected to the housing. This has the advantage that the encoder body can form a shield for its internal circuits. However it permits noise current from the motor body to flow into the encoder cable shield. A good quality shielded cable correctly terminated protects the data against this noise current, but much more care is needed in ensuring correct cable management than for the isolated cases.

Figure 4-7 No isolation

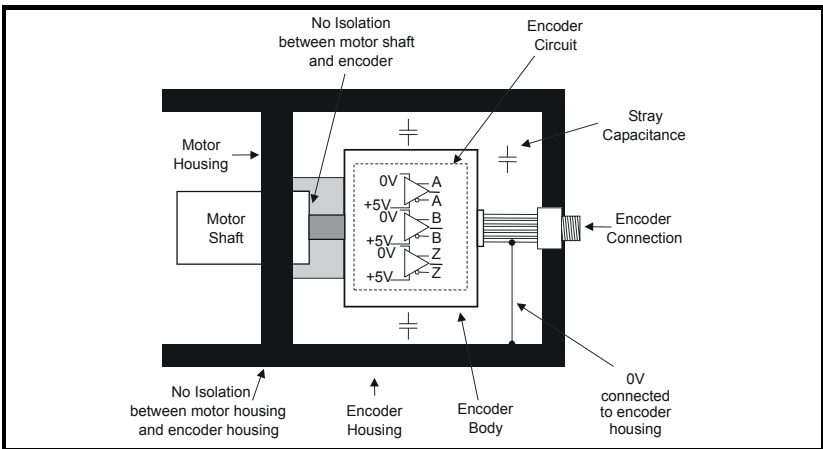

4.3.4 Cable requirements

All mounting methods:

- Shield connection at drive terminal to 0V
- Shield connection at encoder to 0V
- It is recommended that the shielded cable should be run in a continuous length to the terminal, to avoid the injection of noise at intermediate pigtails and to maximise the shielding benefit.
- The shield connections ("pigtails") to the drive and encoder should be kept as short as possible

Mounting with no isolation:

- Shield connected to ground at both ends. The connection must be made by direct fixing of the cable to the grounded metal parts, i.e. to the encoder body and the drive grounding bracket, as illustrated in Figure 4.9. "Pigtails" must be avoided. The outer sheath of the cable should be stripped back enough to allow for the ground clamp to be fitted. The shield connection should not be broken. The ground clamps should be located as close as possible to the drive and encoder.
- It is essential that the shielded cable should be run in a continuous length to the terminal, to avoid the injection of noise at intermediate "pigtails" and to maximise the shielding benefit.



In this case under no circumstances must the cable shield connection be omitted at either end of the cable in this case, since the noise voltage may well be sufficient to destroy the line driver and receiver chips in the encoder and the drive.

Cable shield ground connection

For all mounting methods, grounding of the feedback cable shield has added benefits. It can protect the drive and encoder from induced fast electrical transients, and prevent radiated radio-frequency emission. However it is essential that it be carried out in the correct manner as explained above and shown in Figure 4-9.



Connecting the cable shield to ground at both ends carries the risk that an electrical fault might cause excessive power current to flow in the cable shield and overheat the cable. There must be an adequately rated safety ground connection between the motor/encoder and the drive.

Recommended Cable

The recommended cable for feedback signals is a twisted pair, shielded with an overall shield as shown below.

Figure 4-8 Feedback cable, twisted pair

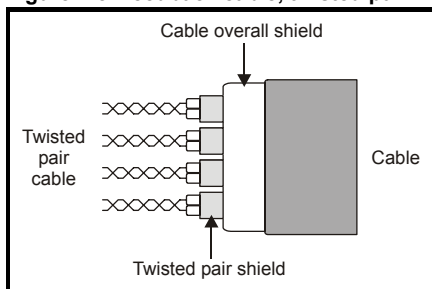

Using this type of cable also allows for the connection of the outer shield to ground and the inner shields to 0V alone at both drive and encoder end, when required.

NOTE

Ensure that feedback cables are kept as far away as possible from power cables and avoid parallel routing.

Figure 4-9 Feedback cable connections

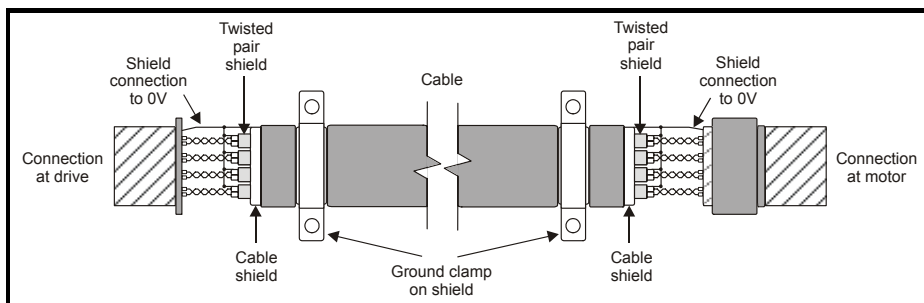

5 Getting started

5.1 Installation



The control circuits are isolated from the power circuits in the drive by basic insulation only, as specified in IEC60664-1. The installer must ensure that the external control circuits are insulated from human contact by at least one layer of insulation rated for use at the AC supply voltage.

If the control circuits are to be connected to other circuits classified as Safety Extra Low Voltage (SELV) (e.g. to a personal computer) an additional isolating barrier must be included in order to maintain the SELV classification.

Encoder connections

In order to ensure correct operation there are a number of checks which should be carried out:

- Ensure the encoder is securely mounted to the motor as spurious operation can result due to the encoder slipping whilst the motor is rotating.
- Ensure encoder connections to both the encoder and the Solutions Module terminals are secured, intermittent connections can result in spurious operation or the Solutions Module not detecting the feedback signals.
- Ensure screening recommendations as specified in Chapter 4.4 Wiring, Shield connections on page 14 are followed to prevent noise being induced on the encoder feedback signals. Noise induced on encoder feedback cables cannot only result in spurious operation but in extreme cases can result in encoder failure and/or damage to the Solutions Modules encoder input.

Encoder feedback and communications data is transmitted from an encoder as low voltage analog or digital signals. Ensure that electrical noise from the drive or motor does not adversely affect the encoder feedback. Ensure that the drive and motor are connected as per the instructions given in the appropriate drive manual, and that the encoder feedback wiring and shielding recommendations are followed in section 4.3 *Wiring, Shield connections* on page 12.

5.2 Incremental set-up

The following parameter set-up should be followed when operating with an Incremental Encoder

Incremental encoders, Ab, Fd and Fr							
Action	Detail						
Before power-up	Ensure: <ul style="list-style-type: none"> • Drive SECURE DISABLE/SAFE TORQUE OFF is not given (terminal 31) • Run signal is not given • Solutions Module is fitted in appropriate slot • Feedback device is connected 						
Power up drive	Ensure: <ul style="list-style-type: none"> • Drive displays 'inh' If the drive trips see Chapter 7 <i>Diagnostics</i> on page 35						
Error detection	Ensure: <ul style="list-style-type: none"> • If no encoder is connected the encoder input on the drive then Pr 3.40 should be set to 0 to disable the drive encoder input wire break detection (Enc2 trip). 						
Slot identification	Identify which Solutions Module slot and menu are being used <ul style="list-style-type: none"> • Slot 1 – Menu 15 • Slot 2 – Menu 16 • Slot 3 – Menu 17 						
Select Solutions Module	Enter: <ul style="list-style-type: none"> • Speed feedback selector Pr 3.26 1: Slot 1 2: Slot 2 3: Slot 3 						
Set-up encoder power supply (SM-Encoder Output Plus only)	Enter:- <ul style="list-style-type: none"> • Encoder power supply Pr x.13. 0: 5V, 1: 8V, 2: 15V 						
Set-up encoder parameters	Enter: <ul style="list-style-type: none"> • Encoder type Pr x.15 0 (Ab) 1 (Fd) 2 (Fr) 						
Set-up encoder lines per revolution	<ul style="list-style-type: none"> • Equivalent lines per revolution Pr x.10 Set according to encoder, see below for restrictions <table border="1" data-bbox="308 869 983 957"> <thead> <tr> <th>Encoder</th> <th>Pr x.10 Equivalent lines per revolution</th> </tr> </thead> <tbody> <tr> <td>Ab</td> <td>Number of lines per revolution</td> </tr> <tr> <td>Fd, Fr</td> <td>Number of lines per revolution / 2</td> </tr> </tbody> </table>	Encoder	Pr x.10 Equivalent lines per revolution	Ab	Number of lines per revolution	Fd, Fr	Number of lines per revolution / 2
Encoder	Pr x.10 Equivalent lines per revolution						
Ab	Number of lines per revolution						
Fd, Fr	Number of lines per revolution / 2						
Initialisation	Ensure: <ul style="list-style-type: none"> • Position feedback is initialised Pr x.45 						

5.3 Simulated encoder output set-up

SM-Encoder Output Plus only

The following parameter set-up should be followed to obtain a simulated encoder output.

Function	Detail
Simulation source	<ul style="list-style-type: none"> Set the source of the simulated encoder output in Pr x.24. x.05: The encoder input on the Solutions Module 3.29: The encoder input on the drive
Simulation ratio	<ul style="list-style-type: none"> Set the required ratio between the source and output lines per revolution in Pr x.25. 1.0000: ratio of 1 0.5000: ratio of 1/2 0.2500: ratio of 1/4 0.1250: ratio of 1/8 0.0625: ratio of 1/16 0.0312: ratio of 1/32
Simulation output mode	<ul style="list-style-type: none"> Set the required encoder simulation mode in Pr x.28. 0: Ab – Quadrature outputs 1: Fd – Frequency and direction outputs 2: Fr – Forward and reverse outputs 3: Ab.L – Quadrature outputs with marker lock 4: Fd.L – Frequency and direction outputs with marker lock

5.4 Freeze function

The SM-Encoder Plus and SM-Encoder Output Plus have a freeze function, but do not have freeze inputs. The freeze function can be activated using either the SM-Applications or SM-Universal Encoder Plus. When a freeze signal is applied, the freeze flag (Pr **x.39**) is set to "ON". When activated, the non-marker position data (Pr **x.29** and Pr **x.30**) is transferred into Pr **x.35** and Pr **x.36**.

The freeze flag does not reset itself. Before carrying out consecutive freeze functions, the SM-Encoder Plus or SM-Encoder Output Plus freeze flag must be cleared by the user (Pr **x.39** = "OFF").

NOTE

If a SM-Universal Encoder Plus is used as a freeze input, it must be set to freeze the drive position by setting Pr **x.40** to "On". Also, before consecutive freeze operations can be performed in the SM-Encoder Plus or SM-Encoder Output Plus, the SM-Universal Encoder Plus freeze flag (Pr **x.39**) must be cleared together with the SM-Encoder Plus or SM-Encoder Output Plus freeze flag (Pr **x.39**).

E.g. If slot 3 has a SM-Universal Encoder Plus fitted and slot 2 has an SM-Encoder Plus fitted, Pr **16.39** and Pr **17.39** need to be set to "OFF" before another freeze function can be performed on the SM-Encoder Plus or SM-Encoder Output Plus.

5.5 Termination resistors

By default the termination resistors on the encoder inputs are enabled with the exception of the marker pulse inputs which are disabled. The termination resistors can be configured as shown below using encoder termination Pr **x.16**.

Terminal	Encoder Input	Pr x.16=0	Pr x.16=1	Pr x.16=2
1, 2	A, A\	Disabled	Enabled	Enabled
3, 4	B, B\	Disabled	Enabled	Enabled
5, 6	Z, Z\	Disabled	Disabled	Enabled

The termination resistance when connected (A, A\) = 120Ω total.

6 Parameters

6.1 Introduction

The parameters listed in this chapter are used for programming and monitoring the SM-Encoder Plus and SM-Encoder Output Plus

The SM-Encoder Plus and SM-Encoder Output Plus are classed as dumb modules as they do not have their own processors, and as a result all parameters are updated by the drive processor.

The SM-Encoder Plus and SM-Encoder Output Plus parameters are read/written by the drive background task or at the combined update time for time critical parameters. The combined update time depends on the number and type of dumb modules fitted to the drive. For each dumb module the update rate of these parameters is specified as either 4 or 8ms. The combined update time is the total of the update times for all dumb modules fitted. (E.g. if two modules with 4ms and 8ms update times are fitted to the drive, then the combined update time for the time critical parameters of each module will be 12ms.)

Dumb module	Update time
SM-I/O Plus	8ms
SM-Encoder Plus	4ms
SM-Encoder Output Plus	4ms
SM-Resolver	4ms

Some functions with the SM-Encoder Plus or SM-Encoder Output Plus modules do not function correctly if the update time is too long. The input frequency should not exceed 500kHz, but in addition the number of encoder counts seen over one sample period should not exceed 32768. Provided the frequency is within the 500kHz limit, the maximum count cannot be exceeded with Fd and Fr encoders with any sample time, or with Ab encoders if the sample time is 16ms or less. If the sample time is 20ms then the maximum allowed frequency with Ab encoders is 409.6kHz.

Position/speed feedback update rate

If the module is selected for motor control position feedback then the position and speed parameters are updated as defined with each parameter, but are available within the drive at a faster rate as shown below.

Control position	Current controller sample rate
Control speed	250us
Position controller position (menu 13)	4ms
Position for SM-Applications module, etc.	250us

If the module is not selected for motor control position feedback the position and speed are updated as defined with the appropriate parameters.

NOTE The same parameter structure is available in menu 15, 16 and 17 referring to slots 1, 2 and 3.



Before attempting to adjust any parameters, refer to Chapter 2 *Safety information* on page 5.

Table 6.1 Key to parameter coding

Coding	Attribute
RW	Read/write: can be written by the user
RO	Read only: can only be read by the user
Bit	1 bit parameter
Bi	Bipolar parameter
Uni	Unipolar parameter
Txt	Text: the parameter uses text strings instead of numbers.
FI	Filtered: some parameters which can have rapidly changing values are filtered when displayed on the drive keypad for easy viewing.
DE	Destination: indicates that this parameter can be a destination parameter.
NC	Not cloned: not transferred to or from smart cards during cloning.
PT	Protected: cannot be used as a destination.
US	User save: saved in drive EEPROM when the user initiates a parameter save.
PS	Power-down save: automatically saved in drive EEPROM at power-down when the under volts (UV) trip occurs.

How to use this guide

Safety information

Introduction

Installing the Solutions Module

Getting started

Parameters

Diagnostics

Terminal data

Index

6.2 Single line descriptions

Parameter	Range(↕)		Default(⇨)			Type						
	OL	CL	OL	VT	SV	RO	Uni	Bi	FI	NC	PT	US
x.01	Solutions Module ID	0 to 599		104			RO	Uni			PT	US
x.03	Speed feedback	±40,000.0 rpm					RO	Bi	FI	NC	PT	
x.04	Revolution counter	0 to 65,535 revolutions					RO	Uni	FI	NC	PT	
x.05	Position	0 to 65,535 (1/2 ¹⁶ ths of a revolution)					RO	Uni	FI	NC	PT	
x.07	Marker position reset disable	OFF (0) or On (1)		OFF (0)			RW	Bit				US
x.08	Marker flag	OFF (0) or On (1)		OFF (0)			RW	Bit		NC		
x.10	Equivalent lines per revolution	0 to 50,000		4,096			RW	Uni				US
x.13*	Encoder supply voltage	0: 5V 1: 8V 2: 15V		0			RW	Uni				US
x.15	Encoder type	Ab (0), Fd (1), Fr (2)		Ab (0)			RW	Uni				US
x.16	Encoder termination	0 to 2		1			RW	Bit				US
x.19	Feedback filter	0 to 5 (0 to 16 ms)		0			RW	Uni				US
x.24*	Encoder simulation source	Pr 0.00 to Pr 21.51		0.00			RW	Uni			PT	US
x.25*	Encoder simulation ratio numerator	0.0000 to 3.0000		0.2500			RW	Uni				US
x.28*	Encoder simulation mode	0: Ab 1: Fd 2: Fr 3: Ab with marker lock 4 to 7: Fd with marker lock		0			RW	Uni				US
x.29	Non-marker reset revolution counter	0 to 65,535 revolutions					RO	Uni		NC	PT	
x.30	Non-marker reset position	0 to 65,535 (1/2 ¹⁶ ths of a revolution)					RO	Uni		NC	PT	
x.32	Marker revolution counter	0 to 65,535 revolutions					RO	Uni		NC	PT	
x.33	Marker position	0 to 65,535 (1/2 ¹⁶ ths of a revolution)					RO	Uni		NC	PT	
x.35	Freeze revolution counter	0 to 65,535 revolutions					RO	Uni		NC	PT	
x.36	Freeze position	0 to 65,535 (1/2 ¹⁶ ths of a revolution)					RO	Uni		NC	PT	
x.39	Freeze flag	OFF (0) or On (1)		OFF (0)			RW	Bit		NC		
x.45	Position feedback initialised	OFF (0) or On (1)					RO	Bit		NC	PT	
x.49	Lock position feedback	OFF (0) or On (1)					RW	Bit				
x.50	Solutions Module error status	0 to 255					RO	Uni		NC	PT	

RW	Read / Write	RO	Read only	Uni	Unipolar	Bi	Bi-polar
Bit	Bit parameter	Txt	Text string	FI	Filtered	DE	Destination
NC	Not cloned	RA	Rating dependent	PT	Protected	US	User save
PS	Power down save						

NOTE *Pr x.13, Pr x.24, Pr x.25 and Pr x.28 are only used when operating with a SM-Encoder Output Plus module. These parameters are not used when operating with a SM-Encoder Plus module

How to use this guide	Safety information	Introduction	Installing the Solutions Module	Getting started	Parameters	Diagnostics	Terminal data	Index
-----------------------	--------------------	--------------	---------------------------------	-----------------	-------------------	-------------	---------------	-------

Figure 6-1 SM-Encoder Plus logic diagram

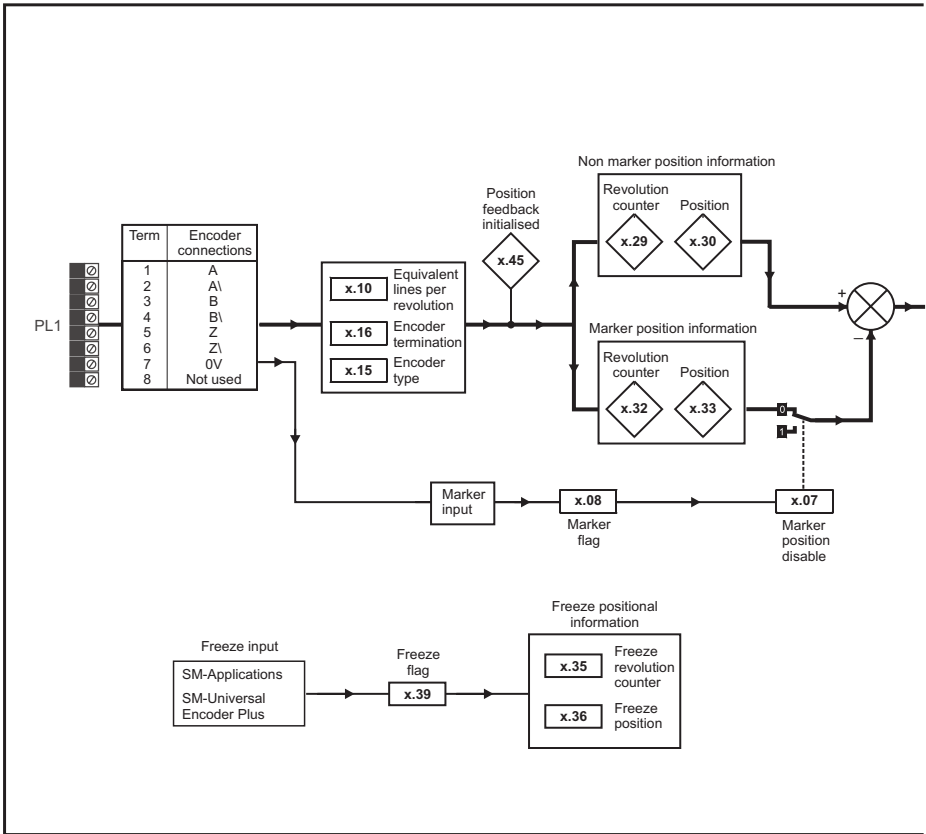

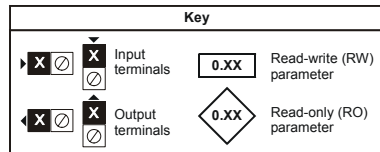
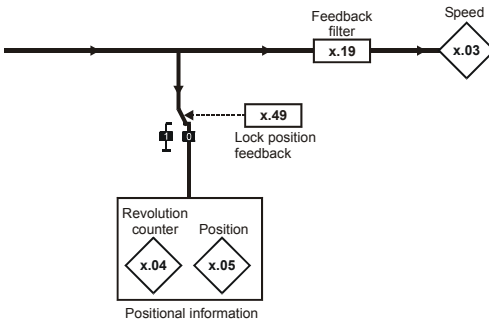

The parameters are all shown at their default settings

Figure 6-2 SM-Encoder Output Plus logic diagram

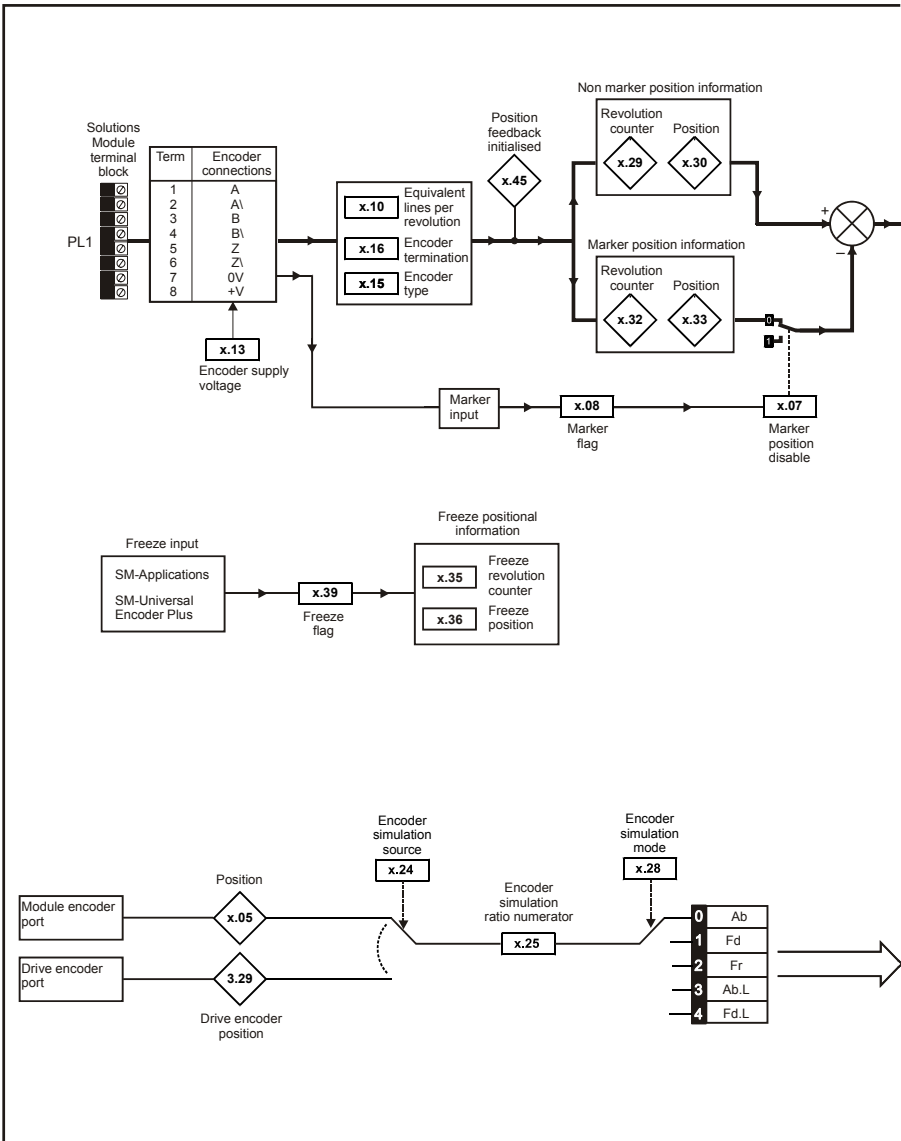

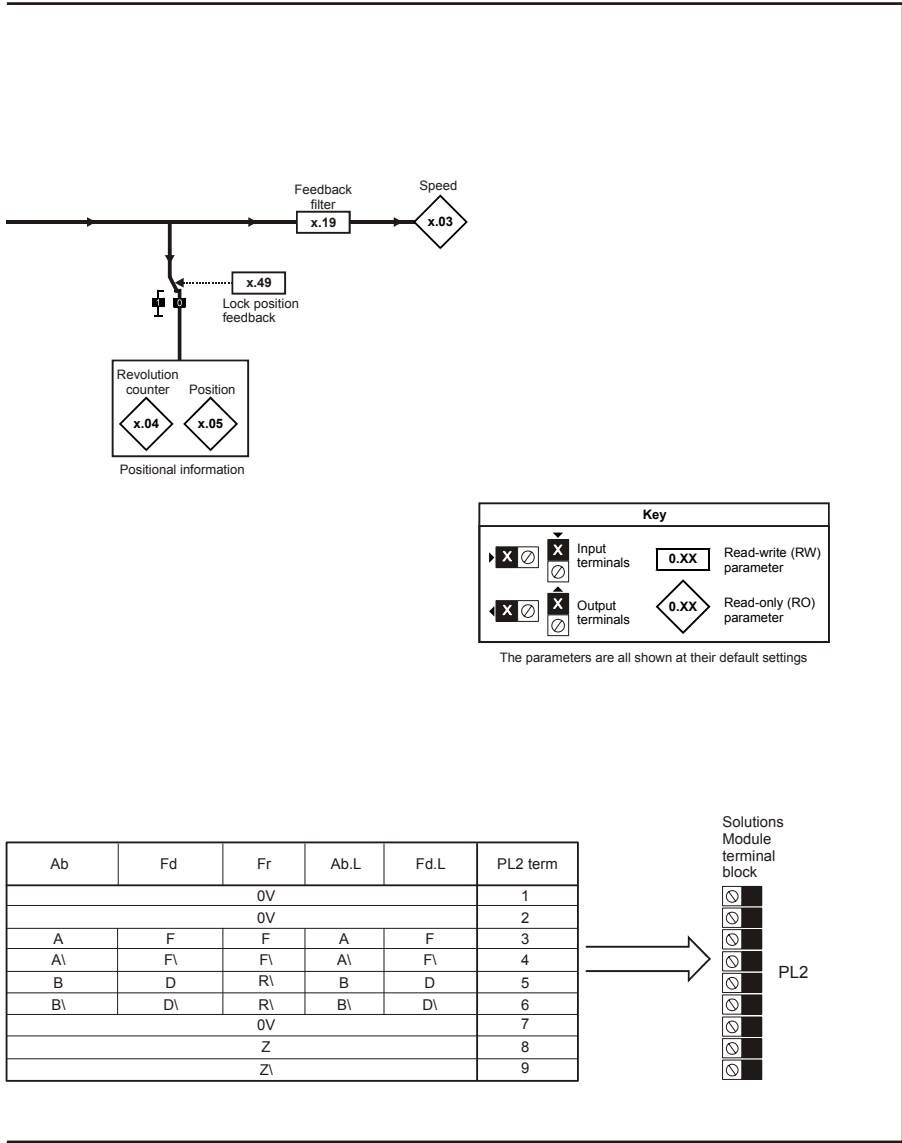

Key

- Input terminals
- Output terminals
- Read-write (RW) parameter
- Read-only (RO) parameter

The parameters are all shown at their default settings

Ab	Fd	Fr	Ab.L	Fd.L	PL2 term
		0V			1
		0V			2
A	F	F	A	F	3
A\	F\	F\	A\	F\	4
B	D	R\	B	D	5
B\	D\	R\	B\	D\	6
		0V			7
		Z			8
		Z\			9

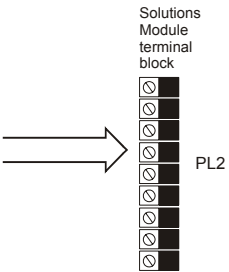

6.3 Parameter descriptions

x.01		Solutions Module ID code							
RO	Uni						PT	US	
↕	0 to 599				⇒	104			
Update rate: Write on power-up									

The menu for the relevant slot appears for the new Solutions Module category with the default parameter values for the new category. When no Solutions Module is fitted in the relevant slot this parameter is zero. When a Solutions Module is fitted this parameter displays the identification code as shown below.

Solutions Module ID	Module	Category
0	No module fitted	
101	SM-Resolver	Feedback
102	SM-Universal Encoder Plus	
104	SM-Encoder Plus and SM-Encoder Output Plus	
201	SM-I/O Plus	Automation (I/O Expansion)
203	SM-I/O Timer	
204	SM-I/O PELV	
205	SM-I/O 24V Protected	
206	SM-I/O 120V	
207	SM-I/O Lite	
208	SM-I/O 32	
301	SM-Applications	Automation (Applications)
302	SM-Applications Lite	
303	SM-EZMotion	
304	SM-Applications Plus	
305	SM-Applications Lite V2	
401	SM-LON	Fieldbus
403	SM-PROFIBUS-DP	
404	SM-INTERBUS	
406	SM-CAN	
407	SM-DeviceNet	
408	SM-CANopen	
409	SM-SERCOS	
410	SM-Ethernet	
501	SM-SLM	SLM

The new parameters values are not stored in EEPROM until the user performs a parameter save. When parameters are saved by the user in the drive EEPROM the option code of the currently fitted Solutions Module is saved in EEPROM. If the drive is subsequently powered-up with a different Solutions Module fitted, or no Solutions Module fitted where one was previously fitted, the drive gives a SLx.dF or SLx.nF trip.

x.03		Speed feedback									
RO	Bi	FI					NC	PT			
↕	±40,000.0 rpm					⇒					
Update rate: 4ms x number of dumb modules											

Provided the set-up parameters for the position feedback are correct this parameter shows the speed in rpm.

x.04		Revolution counter									
RO	Uni	FI					NC	PT			
↕	0 to 65,535 revolutions					⇒					
Update rate: 4ms x number of dumb modules											

x.05		Position									
RO	Uni	FI					NC	PT			
↕	0 to 65,535 ($1/2^{16}$ ths revolutions)					⇒					
Update rate: 4ms x number of dumb modules											

Pr **x.04** and Pr **x.05** give the position with a resolution of $1/2^{16}$ ths of a revolution as a 32 bit number as shown below.

31	16	15	0
Revolutions	Position		

Provided the set-up parameters are correct, the position is always converted to units of $1/2^{16}$ ths of a revolution, but some parts of the value may not be relevant depending on the resolution of the feedback device. For example if 10 bit resolution is selected the resolver produces 4,096 counts per revolution, and so the position is represented by the bits in the shaded area only.

31	16	15	4	3	0
Revolutions	Position				

When the feedback device rotates by more than one revolution, the revolutions in Pr **x.04** increment or decrement in the form of a sixteen bit roll-over counter.

x.07		Marker position reset disable									
RW	Bit									US	
↕	OFF (0) or On (1)					⇒	OFF (0)				
Update rate: Background read											

x.08		Marker flag								
RW	Bit						NC			
⇕		OFF (0) or On (1)				⇒	OFF (0)			
Update rate: 4ms x number of dumb modules										

An incremental digital encoder may have a marker channel and when this channel becomes active (rising edge in the forward direction and falling edge in reverse) it may be used to reset the encoder position and set the marker flag (Pr **x.07** = 0), or just to set the marker flag (Pr **x.07** = 1). When the position is reset by the marker, Pr **x.05** is reset to zero.

The marker flag is set each time the marker input becomes active, but it is not reset by the drive, and so this must be done by the user.

x.10		Equivalent lines per revolution								
RW	Uni							US		
⇕		0 to 50,000				⇒	4,096			
Update rate: Background read (only has any effect when the drive is disabled)										

When Ab, Fd, or Fr signals are used the equivalent number of encoder lines per revolution must be set-up correctly in Pr **x.10** to give the correct speed and position feedback. The equivalent number of encoder lines per revolution (ELPR) is defined as follows:

Position feedback device	ELPR
Ab	number of lines per revolution
Fd, Fr	number of lines per revolution / 2

Although Pr **x.10** can be set to any value from 0 to 50,000, there are restrictions on the values actually used as follows:

If Pr **x.10** < 2, ELPR = 2. If Pr **x.10** > 16,384, ELPR = 16,384. Otherwise, Pr **x.10** is rounded down to the nearest value that is a power of 2, e.g. if 5,000 is set in Pr **x.10**, the drive actually uses 4,096.

x.13		Encoder supply voltage								
RW	Uni							US		
⇕		0 to 2				⇒	0			
Update rate: Background read										

SM-Encoder Output Plus only

The encoder supply voltage for the SM-Encoder Output Plus module is defined by this parameter as 0(5V), 1(8V), or 2(15V).

x.15		Encoder type							
RW	Uni							US	
⇅	Ab (0), Fd (1), Fr (2)			⇒	Ab (0)				
Update rate: 4ms x number of dumb modules									

The following encoders can be connected to the SM-Encoder Plus.

0, Ab: Quadrature incremental encoder, with or without marker pulse

1, Fd: Incremental encoder with frequency and direction outputs, with or without marker pulse

2, Fr: Incremental encoder with forward and reverse outputs, with or without marker pulse

x.16		Encoder termination							
RW	Txt							US	
⇅	0 to 2			⇒	1				
Update rate: Background read									

The terminations may be enabled/disabled by this parameter as follows:

Encoder input	x.16=0	x.16=1	x.16=2
A-A\	Disabled	Enabled	Enabled
B-B\	Disabled	Enabled	Enabled
Z-Z\	Disabled	Disabled	Enabled

x.19		Feedback filter							
RW	Uni							US	
⇅	0 to 5 (0 to 16 ms)			⇒	0				
Update rate: Background read									

A sliding window filter may be applied to the feedback. This is particularly useful in applications where the feedback is used to give speed feedback for the speed controller and where the load includes a high inertia, and so the speed controller gains are very high. Under these conditions, without a filter on the feedback, it is possible for the speed loop output to change constantly from one current limit to the other and lock the integral term of the speed controller. The filter is not active if the parameter value is 0 or 1ms, but operates over the defined window for parameter values of 2, 4, 8 and 16ms.

Value in Pr x.19	Filter window
0	Not active
1	Not active
2	2ms
4	4ms
8	8ms
16	16ms

x.24		Encoder simulation source							
RO	Uni							PT	US
↕	0.00 to 21.51				⇒	0.00			
Update rate: Read on reset									

SM-Encoder Output Plus only

The encoder simulation system provides an encoder output with minimal delay from either the drive encoder (Pr x.24 = 3.29) or the encoder connected to this option module (Pr x.24 equal to any other value). The drive encoder can be an incremental encoder (Ab, Fd, Fr, Ab.Servo, Fd.Servo, Fr.Servo) or it can be a SINCOS encoder (SC, SC.Hiper, SC.EnDat or SC.SSI). If any other encoder types are selected the output is undefined. If a SinCos type encoder is being used the encoder simulation is derived from the sine waves and does not include interpolation information.

x.25		Encoder simulation ratio numerator							
RO	Uni							PT	US
↕	0.0000 to 3.0000				⇒	0.2500			
Update rate: Background read									

SM-Encoder Output Plus only

The ratio between the change of encoder position and the change of encoder simulation output position is defined by Pr x.25. The table below shows the possible ratios.

Pr x.25	Ratio
0.0000 to 0.0312	1/32
0.0313 to 0.0625	1/16
0.0626 to 0.1250	1/8
0.1251 to 0.2500	1/4
0.2501 to 0.5000	1/2
0.5001 to 3.0000	1

For example, if the source encoder has a resolution of 4096 lines per revolution and Pr x.25 set to 0.2500 (a ratio of 1/4), the output resolution will be 1024 lines per revolution.

x.28		Encoder simulation mode							
RO	Uni							US	
↕	0 to 7				⇒	0			
Update rate: Background read									

SM-Encoder Output Plus only

Pr x.28 selects the format of the encoder simulation output as shown in the table below.

Pr x.28	Mode	
0	Ab	Quadrature outputs
1	Fd	Frequency and direction outputs
2	Fr	Forward and reverse outputs
3	Ab.L	Quadrature outputs with marker lock
4 to 7	Fd.L	Frequency and direction outputs with marker lock

The output marker pulse is derived directly from the encoder simulation input source marker pulse. The width of the marker pulse is not adjusted with the encoder simulation ratio, but remains the same width as the input marker pulse. If a mode without marker lock is selected then the relationship between the marker pulse position and the incremental signals is undefined. If a mode with marker lock is selected the incremental position is shifted when the first input marker pulse occurs so that with Ab mode the marker pulse is aligned with A high and B high, and with Fd mode the marker pulse is aligned with F high. Marker lock is required when the system that is receiving the encoder simulation signals requires a defined relationship between the marker pulse and the incremental signals. Marker lock should not be used if the drive encoder equivalent lines per revolution (ELPR) in Pr 3.34, is not a power of 2 or the ELPR of the encoder simulation output is less than 1 after the divide ratio has been applied.

x.29		Non-marker reset revolution counter								
RO	Uni					NC	PT			
⇅	0 to 65,535 revolutions					⇒				
Update rate: 4ms x number of dumb modules										

x.30		Non-marker reset position								
RO	Uni					NC	PT			
⇅	0 to 65,535 (1/2 ¹⁶ ths of a revolution)					⇒				
Update rate: 4ms x number of dumb modules										

This position is taken from the position feedback device and is not affected by the marker or the freeze inputs.

x.32		Marker revolution counter								
RO	Uni					NC	PT			
⇅	0 to 65,535 revolutions					⇒				
Update rate: 4ms x number of dumb modules										

x.33		Marker position								
RO	Uni					NC	PT			
⇅	0 to 65,535 (1/2 ¹⁶ ths of a revolution)					⇒				
Update rate: 4ms x number of dumb modules										

Each time the marker becomes active, the non-marker position values (Pr x.29 and Pr x.30) are sampled and stored in Pr x.32 and Pr x.33.

x.35		Freeze revolution counter								
RO	Uni					NC	PT			
⇅	0 to 65535 revolutions					⇒				
Update rate: 4ms x number of dumb modules										

x.36		Freeze position							
RO	Uni					NC	PT		
↕	0 to 65535 (1/2 ¹⁶ ths of a revolution)				⇒				
Update rate: 4ms x number of dumb modules									

x.39		Freeze flag							
RW	Bit					NC			
↕	OFF (0) or On (1)				⇒	OFF (0)			
Update rate: 4ms x number of dumb modules									

The SM-Encoder Plus and SM-Encoder Output Plus do not have their own freeze inputs, therefore the freeze inputs must come from a SM-Applications or SM-Universal Encoder Plus. The freeze data is processed every 4ms x number of dumb modules fitted. If a freeze has occurred and the freeze flag (Pr **x.39**) is zero, the position data is stored in Pr **x.35** and Pr **x.36** and the freeze flag is set. The freeze flag must be reset by the user before the next freeze event is stored.

x.45		Position feedback initialised							
RO	Bit					NC	PT		
↕	OFF (0) or On (1)				⇒				
Update rate: 4ms x number of dumb modules									

At power-up Pr **x.45** is initially OFF (0), but is set to On (1) when the Solutions Module can provide position feedback. Pr **x.45** then remains at On (1) whilst the drive is powered-up.

x.49		Lock position feedback							
RW	Bit								
↕	OFF (0) or On (1)				⇒				
Update rate: Background write									

If Pr **x.49** is set to one, Pr **x.04** and Pr **x.05** are not updated. If this parameter is zero, Pr **x.04** and Pr **x.05** are updated normally.

x.50		Solutions Module error status							
RO	Uni					NC	PT		
↕	0 to 255				⇒				

The error status is provided so that the only one option error trip is required for each Solutions Module slot. If an error occurs, the reason for the error is written to this parameter and the drive may produce a 'SLX.Er' trip, where X is the slot number. A value of zero indicates the Solutions Module has not detected an error, a non-zero value indicates that an error has been detected. (See Table 7.1 *Trip codes* on page 36 for the meaning of the values in this parameter.) When the drive is reset, this parameter is cleared.

7 Diagnostics

If the drive trips, the output is disabled so that the drive stops controlling the motor. The lower display indicates that a trip has occurred and the upper display shows the trip.

Trips are listed alphabetically in Table 7.1 based on the trip indication shown on the drive display. Refer to Figure 7-1.

If a display is not used, the drive LED Status indicator will flash if the drive has tripped. Refer to Figure 7-2.

The trip indication can be read in Pr 10.20 providing a trip number.

7.1 Displaying the trip history

The drive retains a log of the last 10 trips that have occurred in Pr 10.20 to Pr 10.29 and the corresponding multi-module drive module number (Pr 6.49 = 0) or the trip time (Pr 6.49 = 1) for each trip in Pr 10.41 to Pr 10.51. The time of the trip is recorded from the powered-up clock (if Pr 6.28 = 0) or from the run time clock (if Pr 6.28 = 1).

Pr 10.20 is the most recent trip, or the current trip if the drive is in a trip condition (with the module number or trip time stored in Pr 10.41 and stored in Pr 10.51). Each time a new trip occurs, all the parameters move down one, such that the current trip (and time) is stored in Pr 10.20 (and Pr 10.41 to Pr 10.42) and the oldest trip (and time) is lost out of the bottom of the log.

If any parameter between Pr 10.20 and Pr 10.29 inclusive is read by serial communications, then the trip number in Table 7.1 *Trip codes* on page 36 is the value transmitted.

Figure 7-1 Keypad status modes

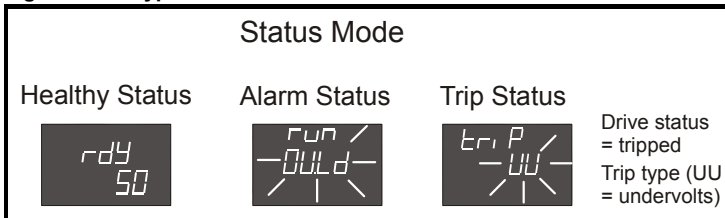
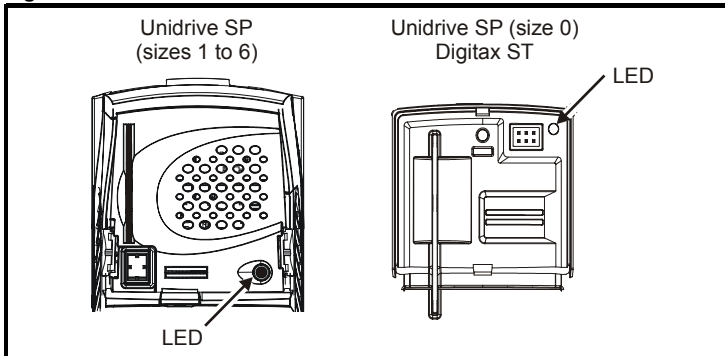

Figure 7-2 Location of the status LED



Non flashing: Normal status

Flashing: Trip status

Any trip can be initiated by writing the relevant trip number to Pr **10.38**. If any trips shown as user trips are initiated the trip string is "txxx", where xxx is the trip number. Trips can be reset after 1.0s if the cause of the trip has been rectified. A full list of drive trips can be found in the appropriate drive manual.

Table 7.1 Trip codes

Trip	Diagnosis						
C.Optn	SMARTCARD trip: Solutions Modules fitted are different between source drive and destination drive						
180	Ensure correct Solutions Modules are fitted Ensure Solutions Modules are in the same Solutions Module slot Press the red  reset button						
Enc1	Drive encoder trip: Encoder power supply overload						
189	Check encoder power supply wiring and encoder current requirement Maximum current = 200mA @ 15V or 300mA @ 8V and 5V						
Enc2	Drive encoder trip: Wire break (Drive encoder terminals 1 & 2, 3 & 4, 5 & 6)						
190	Check cable continuity Check wiring of feedback signals is correct Check encoder power supply is set correctly Replace feedback device If wire break detection on the main drive encoder input is not required, set Pr 3.40 = 0 to disable the Enc2 trip						
PS.24V	24V internal power supply overload						
9	The total user load of the drive and Solutions Modules has exceeded the internal 24V power supply limit. The user load consists of the drive's digital outputs plus the SM-I/O Plus digital outputs, or the drive's main encoder supply plus the SM-Universal Encoder Plus and SM-Encoder Output Plus encoder supplies. <ul style="list-style-type: none"> • Reduce load and reset • Provide an external 24V >50W power supply • Remove any Solutions Modules and reset 						
SLX.dF	Solutions Module slot X trip: Solutions Module type fitted in slot X changed						
204,209,214	Save parameters and reset						
SLX.Er	Solutions Module slot X trip: Error detected with Solutions Module, where X is the slot number						
202 207 212	<table border="1"> <thead> <tr> <th>Pr x.50</th> <th>Fault description</th> </tr> </thead> <tbody> <tr> <td>0</td> <td>No errors</td> </tr> <tr> <td>1</td> <td>Power supply overloaded</td> </tr> </tbody> </table> <p>When the drive is reset this parameter is cleared for the relevant Solutions Module</p>	Pr x.50	Fault description	0	No errors	1	Power supply overloaded
Pr x.50	Fault description						
0	No errors						
1	Power supply overloaded						
SLX.HF	Solutions Module slot X trip: Solutions Module X hardware fault						
200,205,210	Ensure Solutions Module is fitted correctly Return Solutions Module to supplier						

Trip	Diagnosis
SLX.nF	Solutions Module slot X trip: Solutions Module has been removed
203,208, 213	Ensure Solutions Module is fitted correctly Replace Solutions Module Save parameters and reset drive
SLX.tO	Solutions Module slot X trip: Solutions Module watchdog time-out
203,208, 211	Press reset. If the trip persists, contact the supplier of the drive.
SL.rtd	Solutions Module trip: Drive mode has changed and Solutions Module parameter routing is now incorrect
215	Press reset. If the trip persists, contact the supplier of the drive.

How to use this guide

Safety information

Introduction

Installing the Solutions Module

Getting started

Parameters

Diagnostics

Terminal data

Index

8 Terminal data

8.1 Encoder inputs (PL1)

Ab, Fd, and Fr encoders

1	Channel A, Frequency or Forward inputs
2	Channel A\, Frequency\ or Forward\ inputs
3	Channel B, Direction or Reverse inputs
4	Channel B\, Direction\ or Reverse\ inputs
5	Marker pulse channel Z
6	Marker pulse channel Z\
Type	EIA 485 differential receivers
Maximum frequency	500kHz
Line loading	<2 unit loads
Line termination components	120Ω
Working common mode range	+12Vdc to -7Vdc
Absolute maximum applied voltage relative to 0V	±25V
Absolute maximum applied differential voltage	±25V
7	0V Common

8.1.1 SM-Encoder Plus

8	External power supply decoupling
Maximum voltage	±50Vdc

8.1.2 SM-Encoder Output Plus

8	Encoder supply voltage
Supply voltage	5V, 8V or 15V
Maximum output current	300mA for 5V and 8V 200mA for 15V

The encoder supply voltage is controlled by Pr **x.13**. The default for this parameter is 5V (0) but this can be set to 8V (1) or 15V (2). Setting the encoder voltage supply too high for the encoder could result in damage to the feedback device.

The termination resistors should be disabled (Pr **x.16** = 0) if the outputs from the encoder are higher than 5V.

8.2 Encoder Outputs (PL2)

SM-Encoder Output Plus only

Simulated Ab, Fd and Fr encoder output

1	0V Common	
2	0V Common	
3	Channel A, Frequency or Forward	
4	Channel A, Frequency\ or Forward\	
5	Channel B, Direction or Reverse	
6	Channel B, Direction\ or Reverse\	
8	Marker pulse Z	
9	Marker pulse Z\	
Type	EIA 485 differential receivers	
Maximum frequency	500kHz	
Line loading	1 unit load	
Line termination components	120Ω	
Working common mode range	+12V to -7V	
Absolute maximum applied voltage relative to 0V	±25V	
Absolute maximum applied differential voltage	±25V	

How to use this guide

Safety information

Introduction

Installing the Solutions Module

Getting started

Parameters

Diagnostics

Terminal data

Index

Index

C

Cable requirements	15
Cautions	5
Compliance	6

D

Diagnostics	35
-------------------	----

E

Electrical noise	17
Electrical safety	5
Encoder circuit with galvanic isolation from encoder body	13
Encoder inputs - PL1	38
Encoder Outputs - PL2	39
Encoder power supply	30
Encoder simulation output	19
Encoder simulation resolution	32
Encoder type	30, 31
Encoder with galvanic isolation from motor	12
Environmental limits	6
Error status	34

F

Features	7
Feedback cable	15, 17
Feedback cable connections	16
Feedback filter	31
Freeze data	34
Freeze flag	34
Freeze function	19

G

Galvanic isolation	12
--------------------------	----

I

Identification of Solutions Module	7
Incremental encoders	8
Installation	17

K

Keypad status modes	35
---------------------------	----

L

Limitations	8
Line loading - PL1	38
Line loading - PL2	39
Logic diagram - SM-Encoder Output Plus	26
Logic diagram - SM-Encoder Plus	24

M	
Maximum frequency - PL1	38
Maximum frequency - PL2	39
N	
No isolation	14, 15
Notes	5
P	
Parameter - single line descriptions	22
Parameter coding	21
Parameter descriptions	28
Parameter structure	20
Parameters - adjusting	6
Power cables	16
Power supply overload	36
S	
Safety of personnel	5
Set-up parameters	8
Shield connections	12, 15
Solutions Module ID code	28
Solutions Module set-up	18
T	
Terminal data	38
Terminal descriptions	11
Termination - PL1	38
Termination resistors	19
Trip history	35
U	
Update time	20
W	
Warnings	5
Wiring connections	17

How to use this guide
Safety information
Introduction
Installing the Solutions Module
Getting started
Parameters
Diagnostics
Terminal data
Index



0471-0026-04